

1. Features .....	2
2. Applications.....	2
3. Dimension and construction .....	2
4. Power Derating Curve .....	3
5. Rating .....	3
6. Part Number .....	4
7. Resistance Marking / Soldering .....	4
8. Reliability Performance.....	6
9. Packing .....	9
9.1 Peel Strength of Top Cover Tape.....	9
9.2 Tape Packaging Dimensions.....	9
9.3 Reel Dimensions.....	10
10. Storage / Handling .....	10
※. Appendix .....	11

## 1. Features

- High power rating to 0.75W of 1206 size.
- High reliability and high precision.
- Surge performance superior than general thick-film resistors.
- Suitable for lead free soldering.
- Meet AEC-Q200, RoHS compliant & Halogen Free.

## 2. Applications

- Power supply.
- Automotive industry.
- Digital meter, Consumer electronics, M/B.
- LED Lighting.
- Industry control board.

## 3. Dimension and Construction

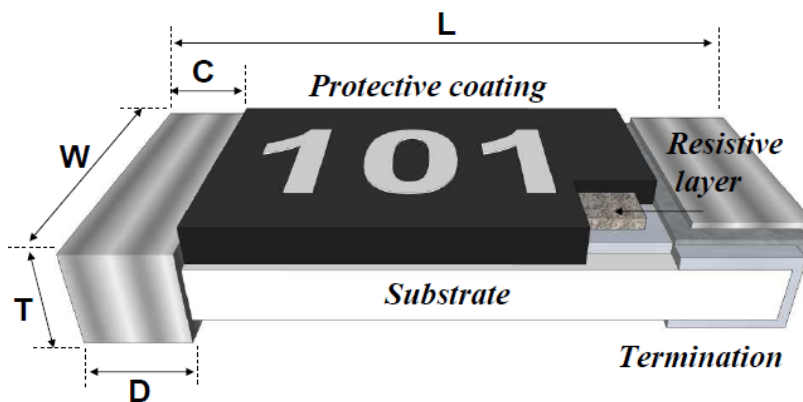

Unit : mm

Type	L	W	C	D	T
FPS03	1.60±0.10	0.80±0.10	0.30±0.20	0.30±0.20	0.45±0.10
FPS05	2.00±0.10	1.25±0.10	0.40±0.20	0.40±0.20	0.50±0.10
FPS06	3.10±0.10	1.60±0.10	0.50±0.25	0.50±0.25	0.55±0.10

#### 4. Power Derating Curve

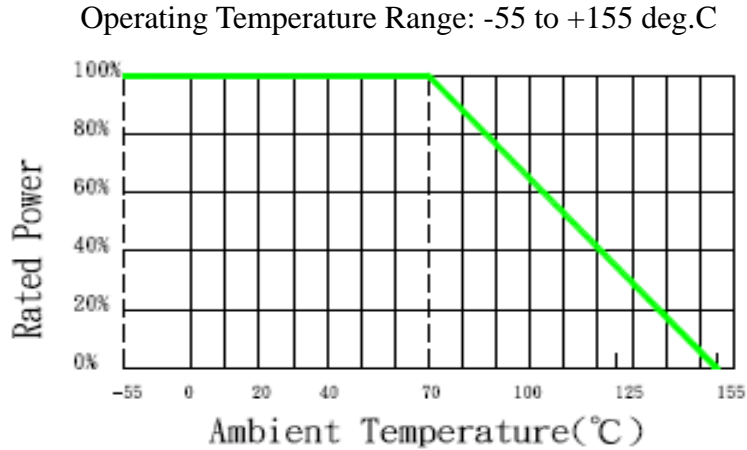

#### 5. Rating

Type	Size	Power Rating at 70°C	Max. RCWV	Max. Overload Voltage	Resistance Tolerance	Temperature Coefficient (ppm/°C)	Resistance Range		Standard Resistance Values
							Min.	Max.	
FPS03	0603	1/3W	75V	125V	±0.5%(D) ±1%(F)	±100ppm	10Ω	1MΩ	E96/E24
					±0.5%(D) ±1%(F)	±200ppm	1Ω	9.76Ω	E96/E24
					±5%(J)	±200ppm	1Ω	1MΩ	E24
FPS05	0805	1/2W	200V	300V	±0.5%(D) ±1%(F)	±100ppm	10Ω	1MΩ	E96/E24
					±0.5%(D) ±1%(F)	±150ppm	1Ω	9.76Ω	E96/E24
					±5%(J)	±200ppm	1Ω	1MΩ	E24
FPS06	1206	3/4W	250V	500V	±0.5%(D) ±1%(F)	±100ppm	1Ω	1MΩ	E96/E24
					±5%(J)	±200ppm	1Ω	1MΩ	E24

Note :  $RCWV = (P \times R)^{1/2}$  or Max. RCWV listed above, whichever is lower.

RCWV : Working Voltage (V) · P : Rated Power (W) · R : Resistance Value (Ω)

Solder-pad and trace size should be evaluated and board surface temperature should not exceed 105°C when applied full rated power.

## 6.Part Number

Type	Size	Tolerance	Packing	Watt	R Value	TCR	Special Code
<b>FPS</b>	<b>03</b> :0603 <b>05</b> :0805 <b>06</b> :1206	<b>D</b> :±0.5% <b>F</b> :±1% <b>J</b> :±5%	<b>Paper Tape :</b> <b>0603.0805.</b> <b>1206</b> <b>T</b> : 5Kpcs <b>V</b> : 10Kpcs <b>W</b> : 20Kpcs	<b>E</b> :1/3W 0603 <b>F</b> :1/2W 0805 <b>G</b> :3/4W 1206	<b>XXXX</b> <b>XXX</b>  <b>±5%:</b> 3 digit  <b>±1%:</b> 4 digit	<b>N</b> :100 <b>Y</b> :150 <b>L</b> :200	<b>" Null "</b> : Standard  <b>M</b> : Meet AEC-Q200

Example :

### FPS08FTF1004N

→0805 size, tolerance 1%, paper tape, 1/2W, 1 MΩ,100ppm, Standard.

### FPS03FTE1000NM

→0603 size, tolerance 1%, paper tape,1/3W, 100Ω,100ppm,Aec-Q200.

### FPS06JTG1R0\_L

→1206 size, tolerance 5%, paper tape, 3/4W, 1Ω, 200ppm, Standard.

## 7.Marking/Soldering

Resistance value identify :

E24 ±5% : 3 Digits marking to identify the resistance value

0603/0805/1206

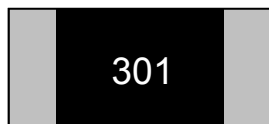

$$301 \rightarrow 30 \times 10^1 = 300\Omega$$

E24/E96 ±0.5,±1% : 4 Digits marking to identify the resistance value

0805/1206

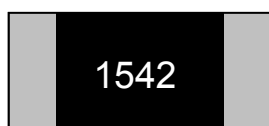

$$1542 \rightarrow 154 \times 10^2 = 15.4 \text{ K}\Omega$$

E24 ±0.5%,±1% : 3 Digits marking to identify the resistance value

0603



222 →  $22 \times 10^2 = 2.2 \text{ K}\Omega$

E96 ±0.5%,±1% : 3 Digits marking to identify the resistance value

0603

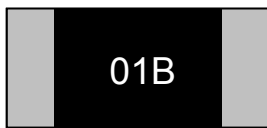

01B → Refer 0603 marking table = 1 KΩ

### Soldering Reference :

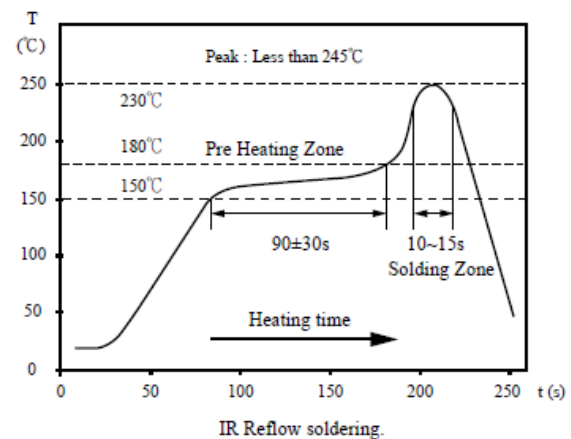
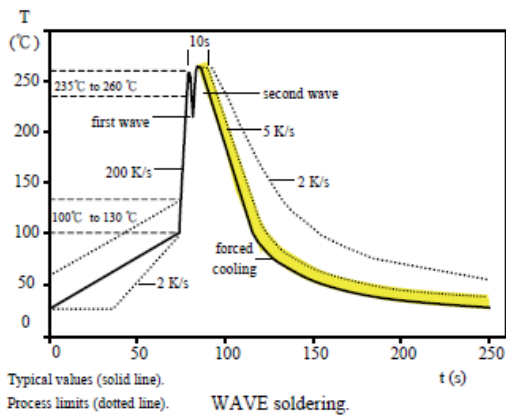

### Recommend Solder Pad Dimensions :

Type	W	D	L
FPS03	0.90	1.00	3.00
FPS05	1.30	1.15	3.50
FPS06	1.80	1.30	4.70

Unit:mm

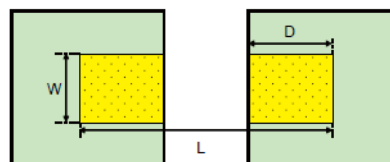

**Surge Performance :**

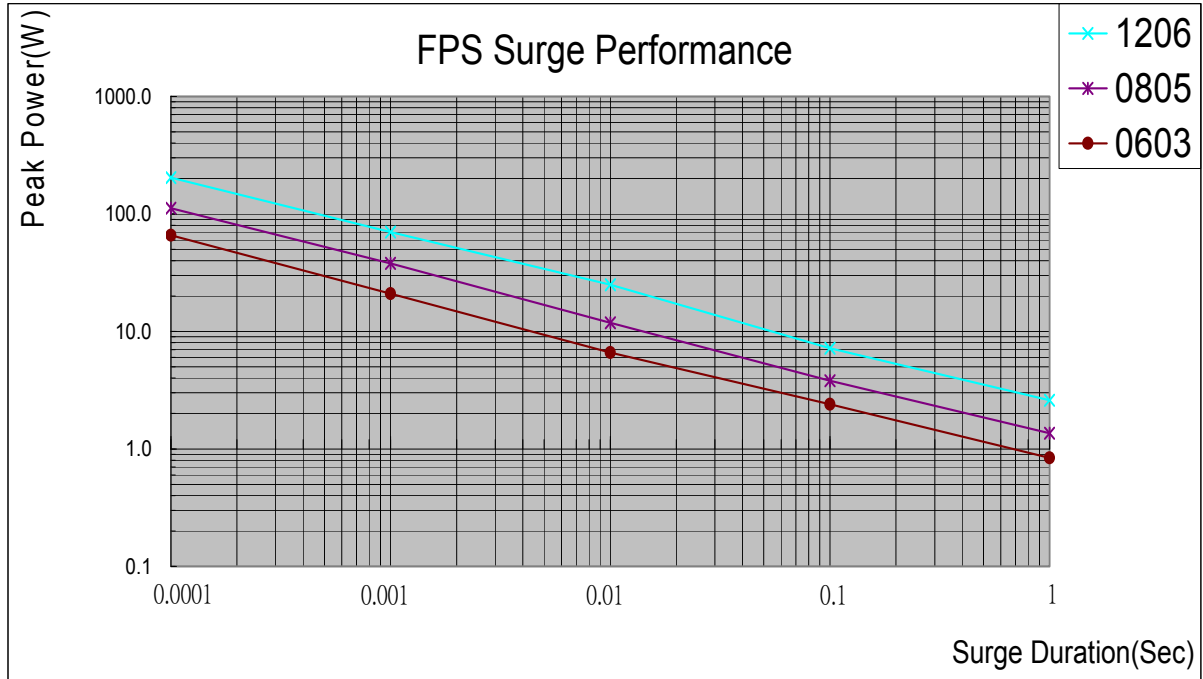

**8. Reliability Performance (AEC-Q200)**

\* Normal test items for standard product.

Test Item	Specification	Test Method (AEC-Q200. IEC 60115)
*DC Resistance	D,F : $\pm 1\%$ ; J : $\pm 5\%$	AEC-Q200 TABLE 7.1 IEC 60115-1 / JIS C 5201-1 , Clause 4.5 Measure the resistance Value.
High Temperature Exposure (Storage)	J : $\Delta R \leq \pm(3\%+0.1\Omega)$ D,F : $\Delta R \leq \pm(1\%+0.05\Omega)$	AEC-Q200 TABLE 7.3 1000 hrs. @ T=125°C. Unpowered. Measurement at 24 $\pm$ 2 hours after test conclusion.
*Temperature Cycling	J : $\Delta R \leq \pm(1\%+0.1\Omega)$ D,F : $\Delta R \leq \pm(0.5\%+0.05\Omega)$ No mechanical damage.	AEC-Q200 TABLE 7.4 1000 Cycles (-55°C to +125°C). Measurement at 24 $\pm$ 2 hours after test conclusion.

**FPS** series. (AEC-Q200)  
**Triple Rated Power / Anti-Surge**  
**Thick-film Lead Free Chip Resistors**

Test Item	Specification	Test Method (AEC-Q200. IEC 60115)
<b>Moisture Resistance</b>	J : $\Delta R \leq \pm(1\%+0.1\Omega)$ D,F : $\Delta R \leq \pm(0.5\%+0.05\Omega)$	<b>AEC-Q200 TABLE 7.6</b> Test 65°C/80~100%RH/10Cycles. Measurement at 24±2 hours after test conclusion. (t=24hrs/cycle).
<b>Biased Humidity</b>	J : $\Delta R \leq \pm(3\%+0.1\Omega)$ D,F : $\Delta R \leq \pm(1\%+0.05\Omega)$	<b>AEC-Q200 TABLE 7.7</b> 1000 hours 85°C/85%RH. 10% of operating power. Measurement at 24 ±2 hours after test conclusion.
<b>Operational Life</b>	J : $\Delta R \leq \pm(3\%+0.1\Omega)$ D,F : $\Delta R \leq \pm(1\%+0.05\Omega)$	<b>AEC-Q200 TABLE 7.8</b> Test 1000hr @ TA=125°C at specified rated power. Measurement at 24±2 hours after test conclusion.
<b>External Visual</b>	No visual damage and refer PDC marking code.	<b>AEC-Q200 TABLE 7.9</b> Inspect device construction, marking and workmanship.
<b>Physical Dimension</b>	Within the spec.	<b>AEC-Q200 TABLE 7.10</b> Verify physical dimensions to the applicable device detail specification.
<b>Mechanical Shock</b>	Within product specification tolerance and no visible damage.	<b>AEC-Q200 TABLE 7.13</b> Test Peak value:100g's,Wave:Hail-sine, Duration:6ms,Velocity:12.3ft/sec.
<b>Vibration</b>	No mechanical damage.	<b>AEC-Q200 TABLE 7.14</b> 5 g's for 20 min., 12 cycles each of 3 orientations. Test from 10-2000 Hz.
<b>*Resistance to Solder Heat</b>	J : $\Delta R \leq \pm(1\% + 0.1\Omega)$ D,F : $\Delta R \leq \pm(0.5\% + 0.05\Omega)$ No mechanical damage.	<b>AEC-Q200 TABLE 7.15</b> Solder dipping @ 270°C±5°C for 10sec.±1sec.
<b>Thermal Shock</b>	J : $\Delta R \leq \pm(1\% + 0.1\Omega)$ D,F : $\Delta R \leq \pm(0.5\% + 0.05\Omega)$ No mechanical damage.	<b>AEC-Q200 TABLE 7.16</b> -55 to 155°C/ dwell time 15min/ Max transfer time 20sec/ 300cycles.
<b>ESD</b>	$\Delta R \leq \pm(1\% + 0.1\Omega)$ No mechanical damage.	<b>AEC-Q200-002</b> Test contact min. 1KV.

# FPS series. (AEC-Q200) Triple Rated Power / Anti-Surge Thick-film Lead Free Chip Resistors

Test Item	Specification	Test Method (AEC-Q200. IEC 60115)
<b>*Solder Ability</b>	Over 95% of termination must be covered with solder.	<b>AEC-Q200 TABLE 7.18</b> a) Baking 155°C 4H, dipping 235°C 5s b) Steam 1H, dipping 215°C 5s c) Steam 1H, dipping 260°C 7s
<b>Flammability</b>	Refer UL-94.	<b>AEC-Q200 TABLE 7.20</b> UL-94 V-0 or V-1 are acceptable
<b>*Board Flex</b>	J : $\Delta R \leq \pm(1\% + 0.1\Omega)$ D,F : $\Delta R \leq \pm(0.5\% + 0.05\Omega)$ No mechanical damage.	<b>AEC-Q200 TABLE 7.21</b> Bending 2mm 1206, 3mm 0805.0603.
<b>Terminal Strength</b>	No mechanical damage	<b>AEC-Q200 TABLE 7.22</b> Force 1 Kg for 60 seconds.
<b>*Short Time Overload</b>	J : $\Delta R \leq \pm(2\% + 0.1\Omega)$ D,F : $\Delta R \leq \pm(1\% + 0.05\Omega)$	<b>IEC 60115-1, Clause 4.13</b> 5 × Rated power for 5 seconds
<b>*Load Life Humidity</b>	J : $\Delta R \leq \pm(3\% + 0.1\Omega)$ D,F : $\Delta R \leq \pm(1\% + 0.05\Omega)$	<b>IEC 60115-1, Clause 4.24</b> 40±2°C with relative humidity 90% ~ 95% D.C. rated voltage for 1.5 hours ON 30 minutes OFF. Cycle repeated 1000 hours.
<b>*Temperature Coefficient of Resistance (TCR)</b>	Within the spec.	<b>IEC 60115-1, Clause 4.8</b> $T_1 \quad T_2$ Test temperature : 25°C ~ -55°C 25°C ~ +155°C $TCR(ppm/^\circ C) = (R_2 - R_1) / R_1 \times 1 / (T_2 - T_1) \times 10^6$
<b>*Load Life</b>	J : $\Delta R \leq \pm(3\% + 0.1\Omega)$ D,F : $\Delta R \leq \pm(1\% + 0.05\Omega)$	<b>IEC 60115-1, Clause 4.25</b> Rated voltage for 1.5 hours for followed by a pause 0.5 hour at 70±2°C. Cycle repeated 1000 hours.
<b>*Insulation Resistance</b>	Between termination and coating must over 1000MΩ	<b>IEC 60115-1, Clause 4.6</b> Test voltage : 100±15V
<b>ESD Characteristic</b>	J : $\Delta R \leq \pm(3\% + 0.1\Omega)$ D,F : $\Delta R \leq \pm(1\% + 0.05\Omega)$	<b>Capacitor discharge Hi-V to resistor.</b> Voltage : ±3kV C : 150pF ( For 1~100Ω)



## 9. PACKAGING

### 9.1 Peel Strength of Top Cover Tape

The peel speed shall be about 300 mm/min

The peel force of top cover tape shall be between 0.1 to 0.7N

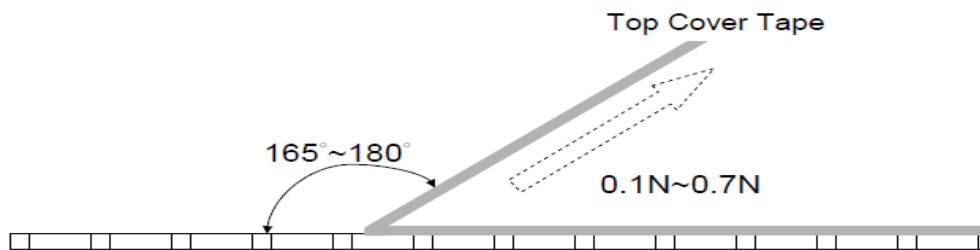

### 9.2 Tape Packaging Dimensions

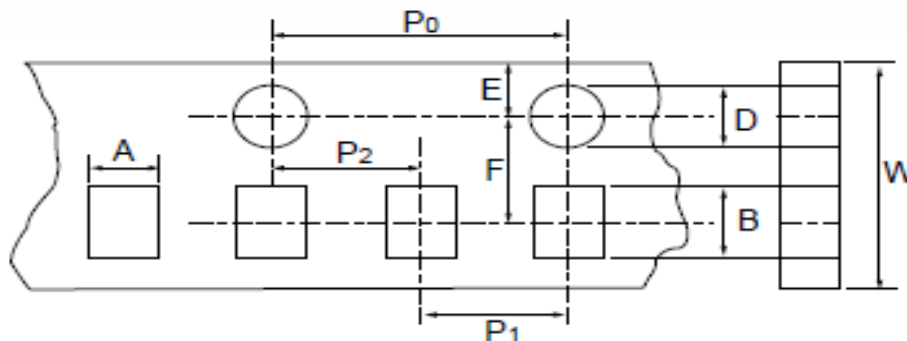

- Accumulated dimensional tolerance  $40 \pm 0.2 \text{mm}$

unit:mm

Size	A	B	W	F	E	P1	P2	P0	D
0603	$1.10 \pm 0.20$	$1.90 \pm 0.20$	$8.00 \pm 0.30$	$3.50 \pm 0.05$	$1.75 \pm 0.10$	$4.00 \pm 0.10$	$2.00 \pm 0.05$	$4.00 \pm 0.10$	$1.50 + 0.10 / -0$
0805	$1.65 \pm 0.20$	$2.40 \pm 0.20$	$8.00 \pm 0.30$	$3.50 \pm 0.05$	$1.75 \pm 0.10$	$4.00 \pm 0.10$	$2.00 \pm 0.05$	$4.00 \pm 0.10$	$1.50 + 0.10 / -0$
1206	$2.00 \pm 0.20$	$3.60 \pm 0.20$	$8.00 \pm 0.30$	$3.50 \pm 0.05$	$1.75 \pm 0.10$	$4.00 \pm 0.10$	$2.00 \pm 0.05$	$4.00 \pm 0.10$	$1.50 + 0.10 / -0$

unit : mm

### 9.3 Reel Dimensions

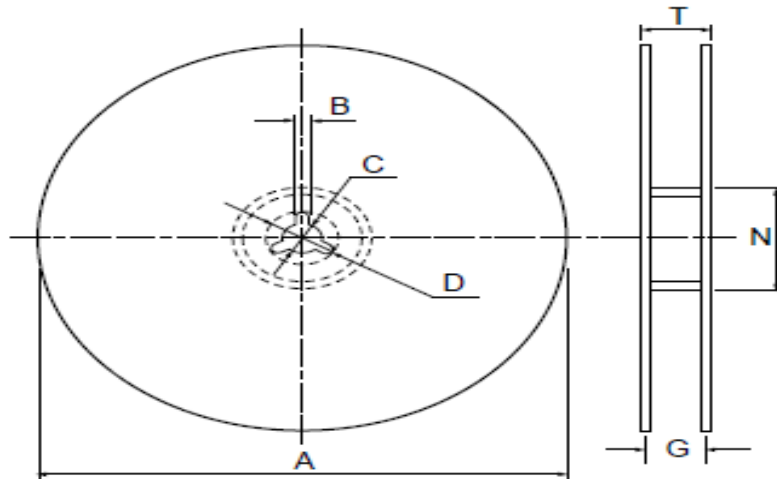

unit:mm								
Size	Packaging Q'ty	A	N	C	D	B	G	T
0603 0805 1206	5kpcs/Reel	178.0±2.0	60.0±0.5	13.0±0.5	20(Min.)	2.0±0.5	10.0±1.5	14.9max.
	10kpcs/Reel	254.0±2.0	100.0±1.0	13.5±0.5	20(Min.)	2.0±0.5	10.0±1.5	14.9max.
	20kpcs/Reel	330.0±2.0	100.0±1.0	13.5±0.5	20(Min.)	2.0±0.5	10.0±1.5	14.9max.

## 10. Storage & Handling

... Products are recommended to be used up within one year as ensured shelf life.

Check solder ability in case shelf life extension is needed.

... To store products with following condition:

Temperature:5 to 40°C ; Humidity: 20 to 70% relative humidity.

### Precaution for use :

The AEC-Q200 series resistors is mainly used on general automotive equipment without safety considerations.

Please contact our company in advanced if you intend to use resistor for designing the equipment which may

damage itself and the safety of third party. If necessary, please consider to add the protect circuit in devising

process and obtaining fully safety evaluation. The contents of the acknowledgment is only used for our parent

company, marketing subsidiaries and official marketing agents who purchase our products. Not applicable for the

other nonofficial channels.

Appendix

■ 0603 1% Marking Table (Table 1)

Code	E48	E96	Code	E48	E96	Code	E48	E96	Code	E48	E96
01	100	100	25	178	178	49	316	316	73	562	562
02		102	26		182	50		324	74		576
03	105	105	27	187	187	51	332	332	75	590	590
04		107	28		191	52		340	76		604
05	110	110	29	196	196	53	348	348	77	619	619
06		113	30		200	54		357	78		634
07	115	115	31	205	205	55	365	365	79	649	649
08		118	32		210	56		374	80		665
09	121	121	33	215	215	57	383	383	81	681	681
10		124	34		221	58		392	82		698
11	127	127	35	226	226	59	402	402	83	715	715
12		130	36		232	60		412	84		732
13	133	133	37	237	237	61	422	422	85	750	750
14		137	38		243	62		432	86		768
15	140	140	39	249	249	63	442	442	87	787	787
16		143	40		255	64		453	88		806
17	147	147	41	261	261	65	464	464	89	825	825
18		150	42		267	66		475	90		845
19	154	154	43	274	274	67	487	487	91	866	866
20		158	44		280	68		499	92		887
21	162	162	45	287	287	69	511	511	93	909	909
22		165	46		294	70		523	94		931
23	169	169	47	301	301	71	536	536	95	953	953
24		174	48		309	72		549	96		976

Code	A	B	C	D	E	F	G	H	X	Y	Z
Multiplier	$10^0$	$10^1$	$10^2$	$10^3$	$10^4$	$10^5$	$10^6$	$10^7$	$10^{-1}$	$10^{-2}$	$10^{-3}$

※ All product specification and data are subject to change without notice.